

SECTION A



DC MOTOR OPTIONS



Plastic cover for DC motors Ø 114
Weight: 0,27 kg

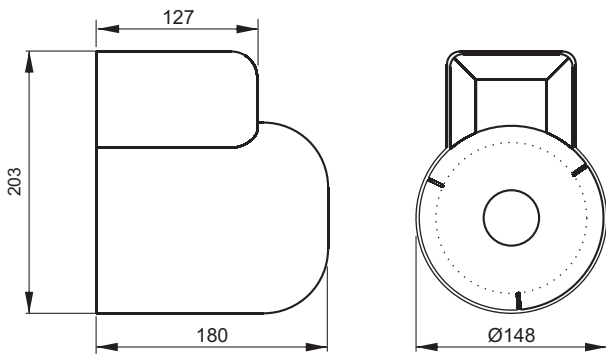

Assembly code	Spare part code
MC	F1600001



Wired remote control
Weight: 0,60 kg Max Current @ Voltage:
Protection degree: IP65 2A@400VAC; 5A@220VAC/24VDC/12VDC

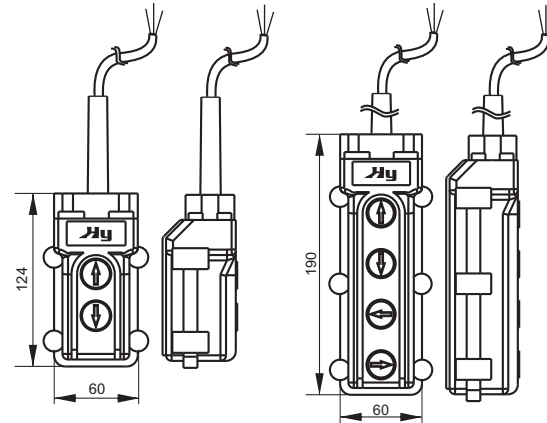

Description	Spare part code
Wired remote control with 2 buttons single/double acting	P0201
Wired remote control with 4 buttons double acting	P0202



Mounting kit for DC motors

Motor Type	Mounting Kit code	Mounting kit sub-parts	
		Power cable	Fixing system
Ø 80	M47SK0801	M47SK000A	Clamp band E60513080
Ø 114	M47SK1121	M47SK000C	Screws TCEIM5X10 + washer WASHL05
Ø 125 - 151	M47SK1251	M47SK000E	Screws TCEIM5X10 + washer WASHL05

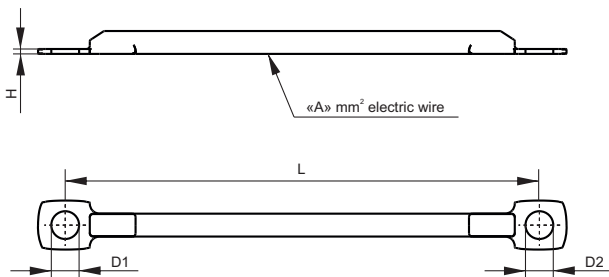

Power Cables

Spare part	L (mm)	A (mm ²)	D1 (mm)	D2 (mm)	H (mm)
M47SK000A	130	10	6	8	1,5
M47SK000B	130	2	6	5	1,5
M47SK000C	130	16	8	8	2
M47SK000D	130	2	8	5	1,5
M47SK000E	130	25	10	8	2
M47SK000F	130	2	10	Faston 6,3 mm	1,5