

SECTION A



MOUNTING KIT FOR FRAME 80 B14 IEC MOTORS



Kit weight: 0,36 Kg

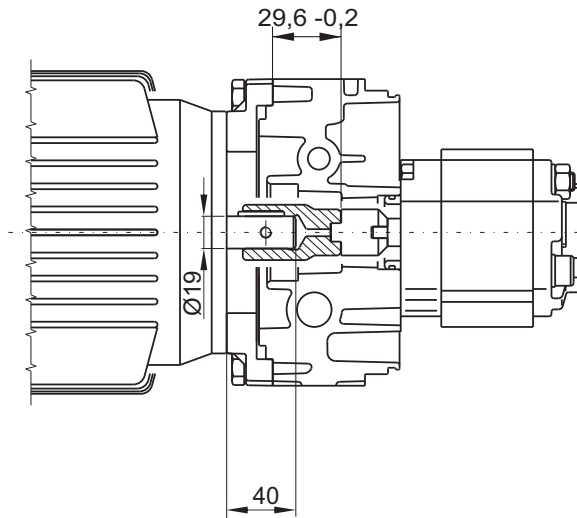

Adaptor flange

Adaptor flange **F27010002** Weight: 0,21 Kg

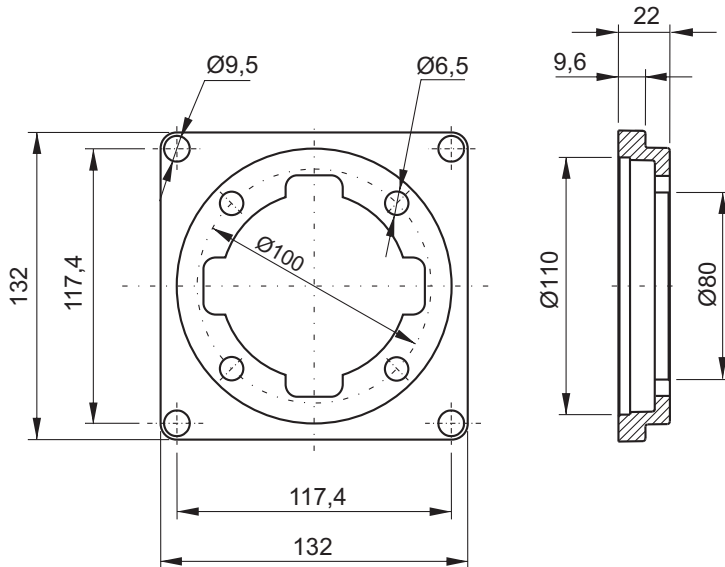

Couplings

Pump side (group1) **E36100000** Weight: 0,05 Kg

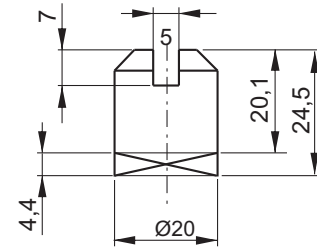

Pump side (group0) **E36100006** Weight: 0,04 Kg

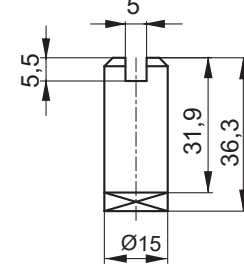

Motor side **E36100002** Weight: 0,12 Kg

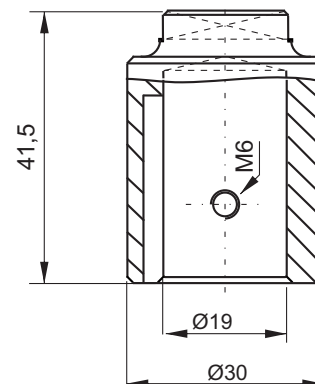

Description	Assembly code*	Spare part code
B14 80 motor side half-coupling	XB14 80 -0 (gr.0) -1 (gr.1)	E36100002
B14 pump side half-coupling		E36100006 (gr.0) E36100000 (gr.1)
B14 80 adaptor flange		F27010002

* Note: The coupling+flange kit is already included when specifying a B14 motor in PPC assembly code. XB14 80 code has to be indicated only when ordering PPC with no motor but with coupling+flange kit.

For increased IP protection degree with B14 flanges you can add the optional bracket code MP001.

Attention! When assembling frame 80 B14 motors with XB14 flange+couplings kit, please respect positioning tolerances as per top drawing. Failure to do so can cause malfunctioning or component failure.