

MOUNTING KIT FOR FRAME 90 B14 IEC MOTORS

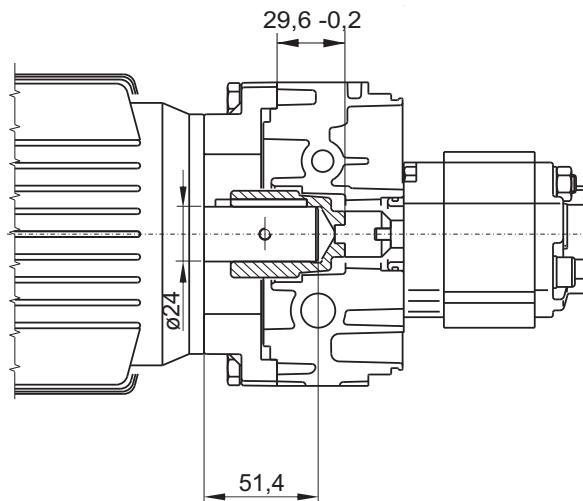

Kit weight: 0,59 Kg



Adaptor flange

Adaptor flange **F27010003** Weight: 0,35 Kg

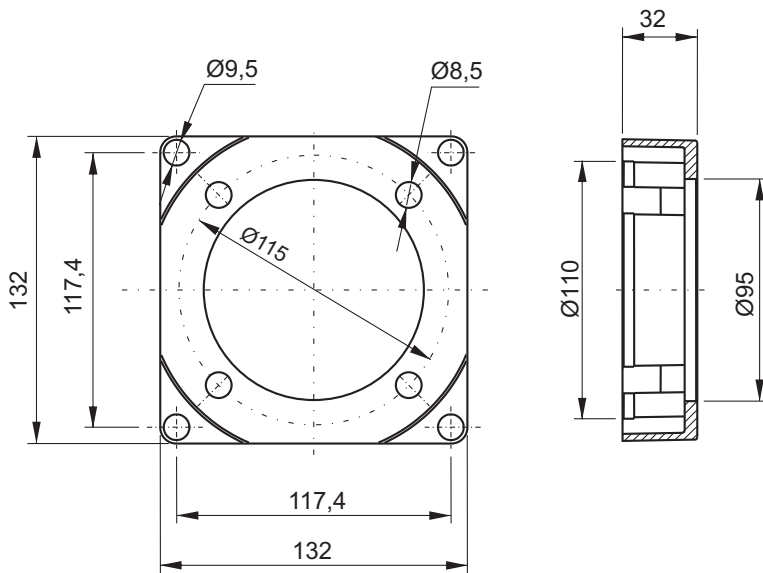

Couplings

Pump side **E36100000** Weight: 0,05 Kg

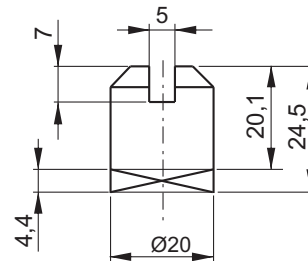

Motor side **E36100003** Weight: 0,22 Kg

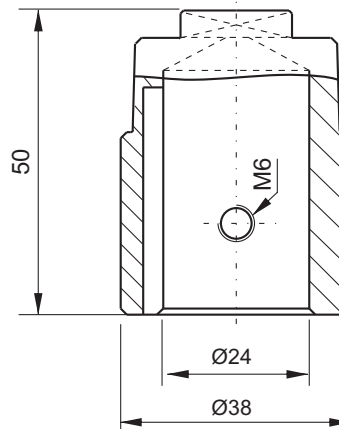

Description	Assembly code*	Spare part code
B14 90 motor side half-coupling	XB14 90-1	E36100003
B14 pump side half-coupling		E36100000
B14 90 adaptor flange		F27010003

* Note: The coupling+flange kit is already included when specifying a B14 motor in PPC assembly code. XB14 90 code has to be indicated only when ordering PPC with no motor but with coupling+flange kit.

For increased IP protection degree with B14 flanges you can add the optional bracket code MP001.

Attention! When assembling frame 90 B14 motors with XB14 flange+coupling kit, please respect positioning tolerances as per top drawing. Failure to do so can cause malfunctioning or component failure.